

# Maintenance-free pulsation dampening Resonators

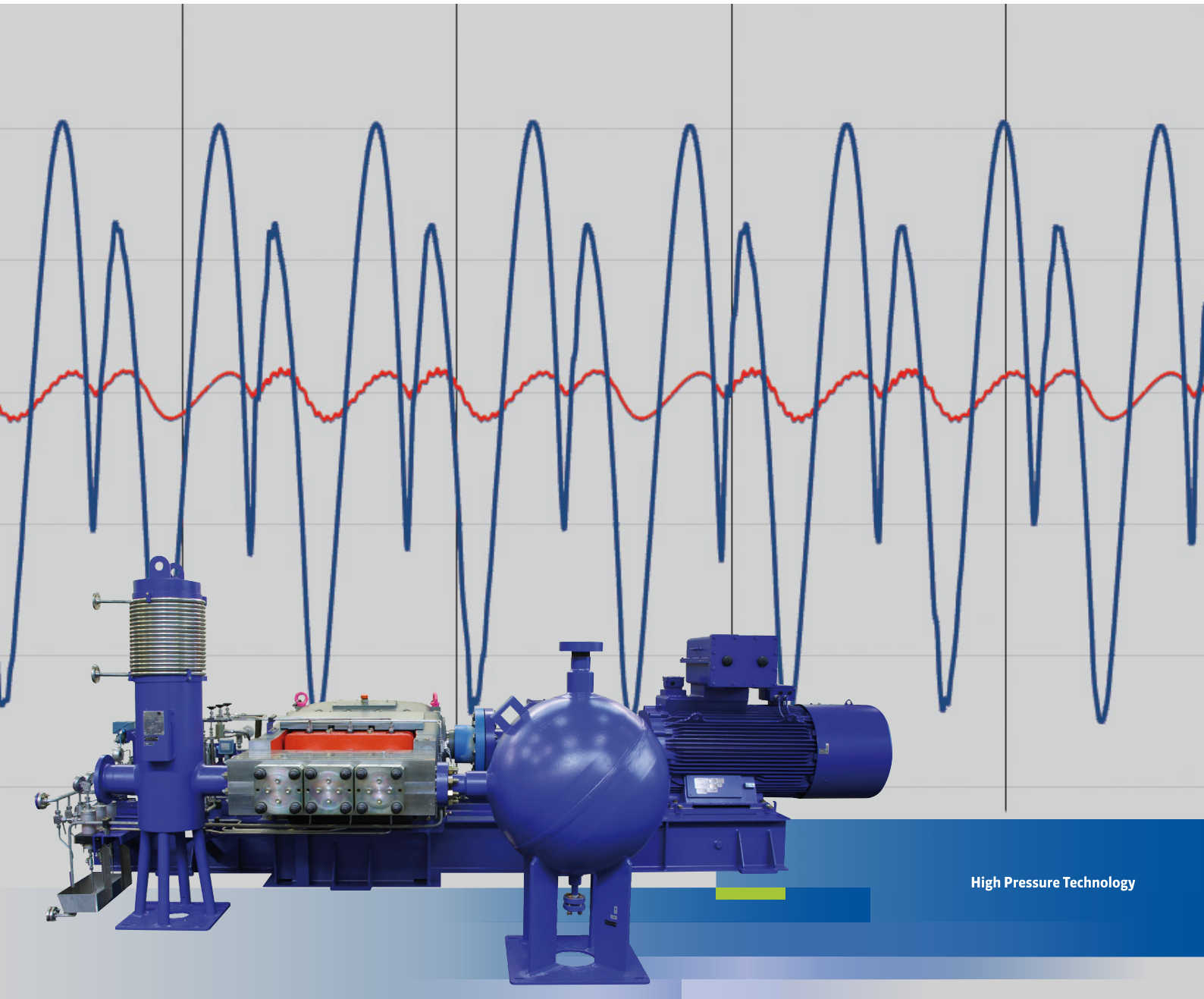

High Pressure Technology

## Resonators for the pulsation damping on plunger pumps

Pressure pulsations on high pressure pumps often have to be reduced to meet the requirements of the installation. Resonators, i.e. pulsation dampers, are most suitable for this purpose. Contrary to hydro pneumatic dampers, resonators are maintenance-free as they do not have any moving parts, bladders or diaphragms nor require any gas filling. The pulsation damping is due to the partial reflection of the pressure waves in the resonator. Resonators give excellent damping results within a wide range of pressures and pump speeds. Their functional efficiency at low and very high temperatures is of great importance particularly where aggressive fluids are used.

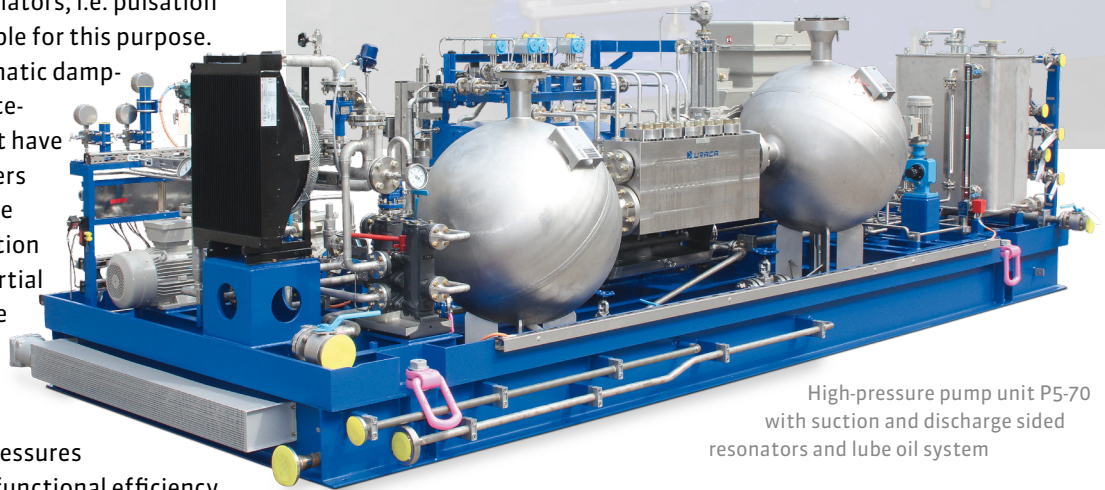

High-pressure pump unit P5-70 with suction and discharge sided resonators and lube oil system

## Measured pressure regulations

Triplex plunger pump with cylindrical resonator ( $Q=14,7 \text{ l/min}$ ,  $n=257 \text{ min}^{-1}$ )

Pressure variation (bar)

Operating pressure (bar)

Pressure variation (bar)



Without resonator damping

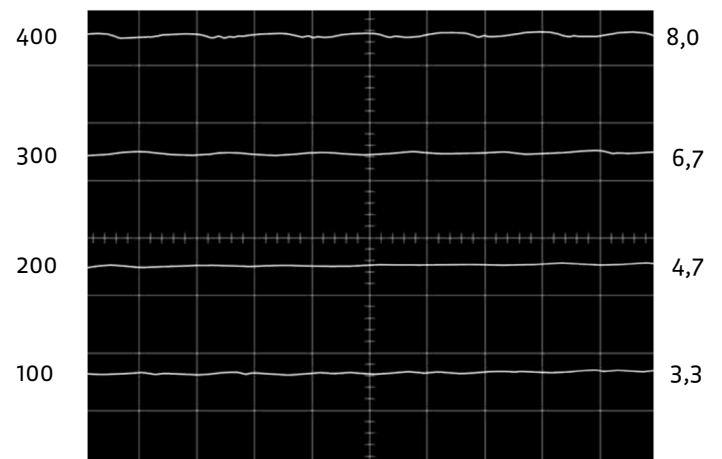

With resonator damping

1 bar = 14,5038 psi; 1 l/min = 0,26417 USGPM = 0,22 IPGPM; 1 kW = 1,3410 HP; 1 mm = 0,03937 inch

## Choice of design

The choice of design (cylindrical or spherical) has little influence on the function of the resonator. Normally the choice is made on the basis of the manufacturing facilities for the resonator and also any site restrictions and requirements of the pump installation.

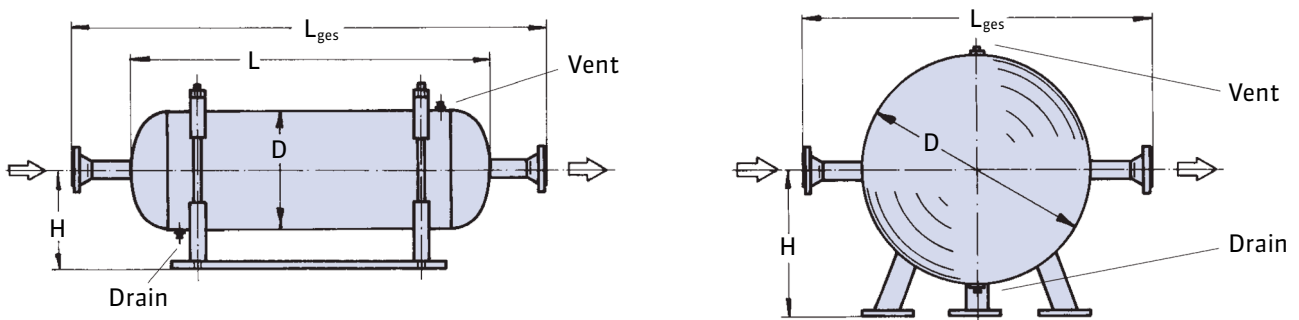

## Characteristics of various pulsation damper designs

Design of the resonator	Bladder accumulator	Diaphragm accumulator	Air bottle	Single chamber resonators Cylindrical	Spherical
Wear and tear	Yes		Minimal	No	
Servicing	Regular checks on precharge pressure necessary			None	
Medium having high temperatures (>120°C)	Not suitable		Not affected	Non affected	
Variable operating pressure	Precharge pressure must be adjusted accordingly			Largely unaffected	
High pressures (>350 bar)	Increasingly unsuitable			Non affected	
Low pressures (<50 bar)	Increasingly suitable			Increasingly unsuitable	
High pump speeds (>500 min <sup>-1</sup> )	Increasingly unsuitable			Suitable	
Low pump speeds (<100 min <sup>-1</sup> )	Increasingly suitable			Increasingly unsuitable	
Suitable for suction side	Suitable			Very good for reducing pressure pulsations Not suitable for improving NPSH	

## Testing and inspection

Depending on pressure, volume, temperature and liquid the resonators have to comply with local rules. Inspection and testing can be certified accordingly.

## Recommendations regarding the installation of resonators

Installation on discharge side of plunger pump:  
Do not install any shut-off and control valves between pump and resonator.

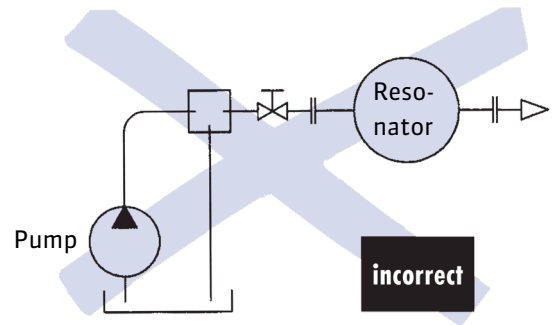
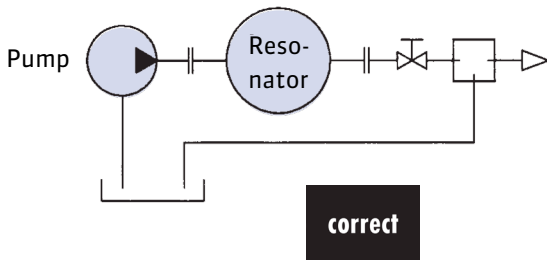

Distance between pump and resonator has to be as short as possible. Min. radius of 90° pipe bends not to be below 5 times of the pipe diameter.

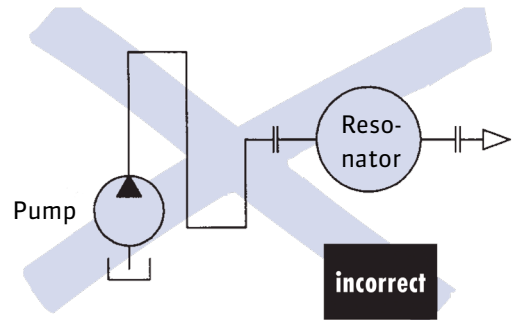
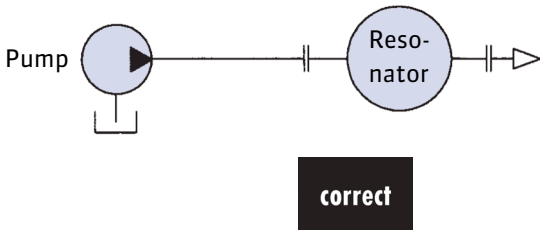

Possible ways of installation:

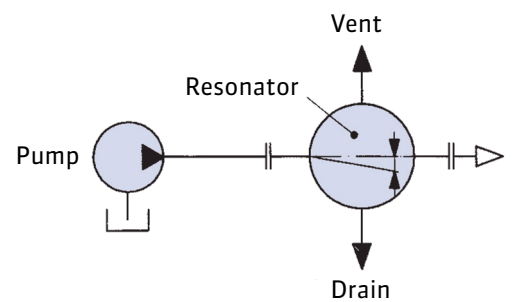
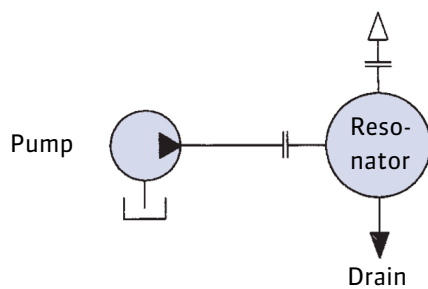

Design may be subject to modification. Dimensions, weights, illustrations and technical data are without engagement.